

Thermodyne's 700NDNL counter-top holding unit provides food quality and kitchen efficiency like no other piece of equipment on the market today. Using patented Fluid Shelf® technology each shelf in the cabinet maintains an exact temperature, allowing for extended holding times, without sacrificing appearance or taste. The 700NDNL has twice the capacity of our 300NDNL model and also requires no door. Units are available as pass through or with a solid panel back and include our exclusive removable floating lid system.



SPECIFICATIONS	
EXTERIOR DIMENSIONS	774.70W x 584.20D x 692.15H
INTERIOR DIMENSIONS	673.10W x 558.80D x 514.35H
MAX OPERATING TEMP	110°C
NET WEIGHT	78.5kg.
SHIPPING WEIGHT	105.7kg.

ELECTRICAL SPECIFICATIONS			
VOLTS	220	230	240
AMPS	11	12	13
TOTAL WATTS	2520	2755	3000
HERTZ	50	50	50
PHASE	1	1	1
PLUG	BS1363/A		

SHELVES	
STANDARD	5

CAPACITY	
STEAM TABLE PAN	
12" x 20" x 2.5"	10

OPTIONS / ACCESSORIES	
High Temp Pans	Vented Stainless Drawer Lids
Controller Shield	Stainless Steel Drip Pan
Pass-thru	Stainless Drawer Lids
Wire Baskets	Stainless Steel Riser

700CT - Model includes doors	
EXTERIOR DIMENSIONS	30.50"W x 24.75"D x 27.25"H
NET WEIGHT	189lbs.
SHIPPING WEIGHT	265lbs.

Specifications subject to change without notice.

FRONT VIEW

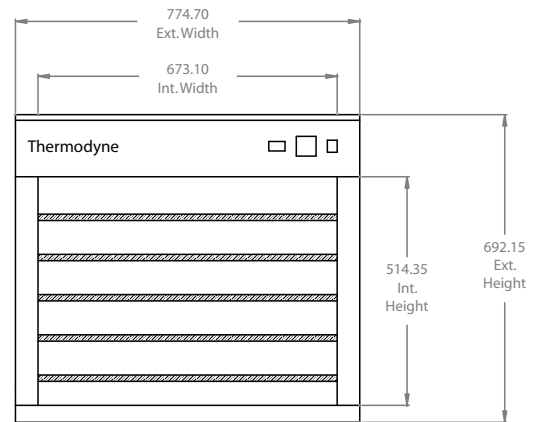

SIDE VIEW

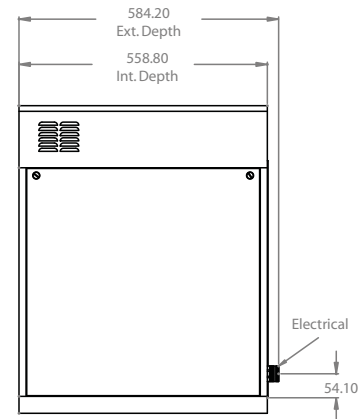

PLAN VIEW

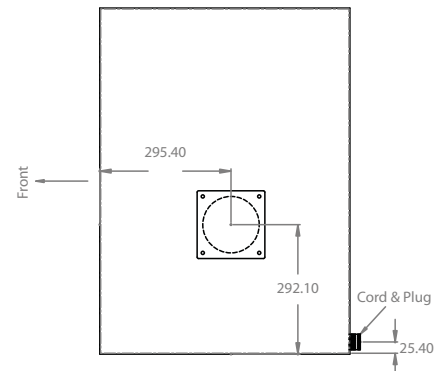

700CT

