

Designed as a dimensional alternative to the 1200G, Thermodyne's 1200DW offers additional space for side by side pan placement along with double doors for tight areas that require a narrow door swing. The 1200DW offers all of the benefits of Fluid Shelf® technology in a compact single stack unit and can be ordered with an optional base extension.



SPECIFICATIONS	
EXTERIOR DIMENSIONS	774.70W x 657.35D x 1085.85H
INTERIOR DIMENSIONS	673.10W x 571.50D x 742.95H
MAX OPERATING TEMP	110°C
NET WEIGHT	112.9kg.
SHIPPING WEIGHT	163.3kg.

ELECTRICAL SPECIFICATIONS			
VOLTS	220	230	240
AMPS	11	12	13
TOTAL WATTS	2520	2755	3000
HERTZ	50	50	50
PHASE	1	1	1
PLUG	BS1363/A		

SHELVES	
STANDARD	5

CAPACITIES	STANDARD	MAXIMUM*
SHEET PAN		
18" x 26" x 1"	5	10
STEAM TABLE PAN		
12" x 20" x 2.5"	10	14
12" x 20" x 4"	10	10

*Maximum capacities are based on additional shelving. Capacities vary depending on shelf quantities, spacing, and pan depth.

OPTIONS / ACCESSORIES	
Protective Bumper Base	Additional Heat Transfer Plates
Extension Base	Solid Stainless Steel Doors
Solid Back Panel	Stainless Steel Drip Pan

Specifications subject to change without notice.

FRONT VIEW

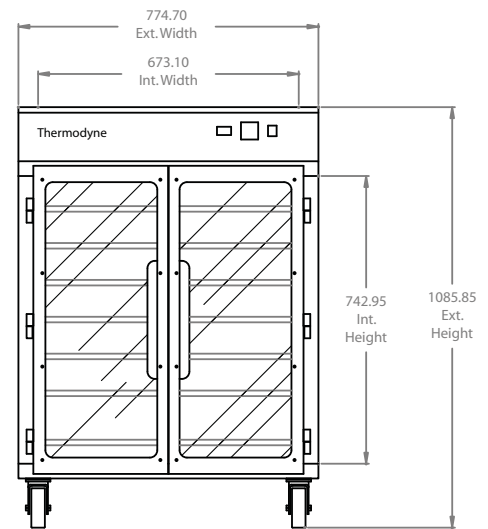

SIDE VIEW

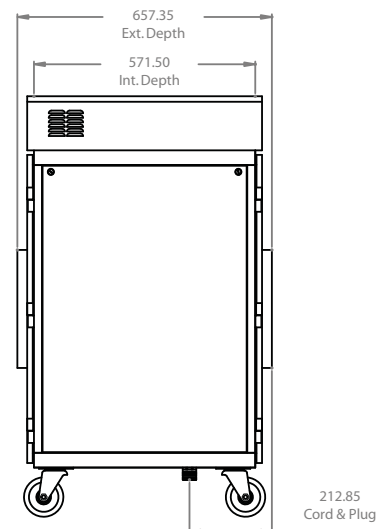

PLAN VIEW

